

NR, NR4

Pompes in-line



 **calpeda**[®]

Exécution

Electropompes centrifuges à un étage, monobloc avec accouplement direct moteur-pompe et arbre unique.
Corps de la pompe à volute avec les orifices d'aspiration et de refoulement avec le même diamètre et situés sur le même axe (exécution "in-line").

Orifices: Brides PN 10, EN 1092-2.

Contre-brides (sur demande)

Modèles	Brides
NR 50, NR 65	Brides filetées PN 16, EN 1092-1
NR 80, NR 100, NR 125	Brides à souder par superposition PN 10, EN 1092-1

Utilisations

Pour liquides propres sans particules abrasives, non agressifs pour les matériaux de la pompe (avec parties solides jusqu'à 0,2% max).
Pour les installations de chauffage, conditionnement, refroidissement.
Pour applications civiles et industrielles.
Lorsqu'il est demandé une marche silencieuse (n = 1450 1/min).

Limites d'utilisation

Température du liquide -10 °C à +90 °C.
Température ambiante jusqu'à 40 °C.
Hauteur d'aspiration manométrique jusqu'à 7 m.
Pression finale maximum admise dans le corps de la pompe 10 bar.
Service continu.

Moteur

Moteur à induction à 4 pôles, 50 Hz (n = 1450 1/min).

NR4: triphasé 230/400 V ± 10% jusqu'à 3 kW;
400/690 V ± 10% pour 4 kW.

NR4M: monophasé 230 V ± 10%.

Moteur à induction à 2 pôles, 50 Hz (n = 2900 1/min).

NR: triphasé 230/400 V ± 10% jusqu'à 3 kW;
400/690 V ± 10% de 4 à 18,5 kW.

NRM: monophasé 230 V ± 10%.

Isolation classe F.

Protection IP 54.

Exécution selon IEC 60034.

Matériaux

Composant	Matériau
Corps pompe Lanterne de raccord.	Fonte GJL-200 EN 1561
Roue	Fonte GJL-200 EN 1561 (Laiton P-Cu Zn 40 Pb 2 UNI 5705 pour NR-NR4 50, NR-NR4 50/200)
Arbre	Acier au Cr-Ni AISI 303 pour pompes jusqu'à 1,1kW Acier au chrome AISI 430 pour pompes de 1,5 à 4 kW
Garniture mécanique	Carbon - Céramique - NBR
Contre-brides	Acier Fe 430B UNI 7070

Exécutions spéciales sur demande

- Autres voltages.
- Fréquence 60 Hz.
- Protection IP 55.
- Garniture mécanique spéciale.
- Pour liquide ou ambiante avec températures plus élevées ou plus basses.

Graphique d'utilisation

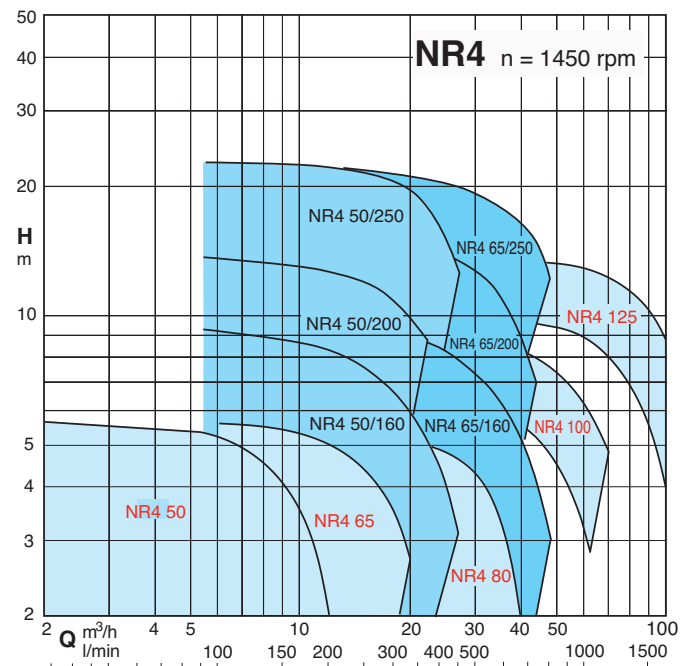
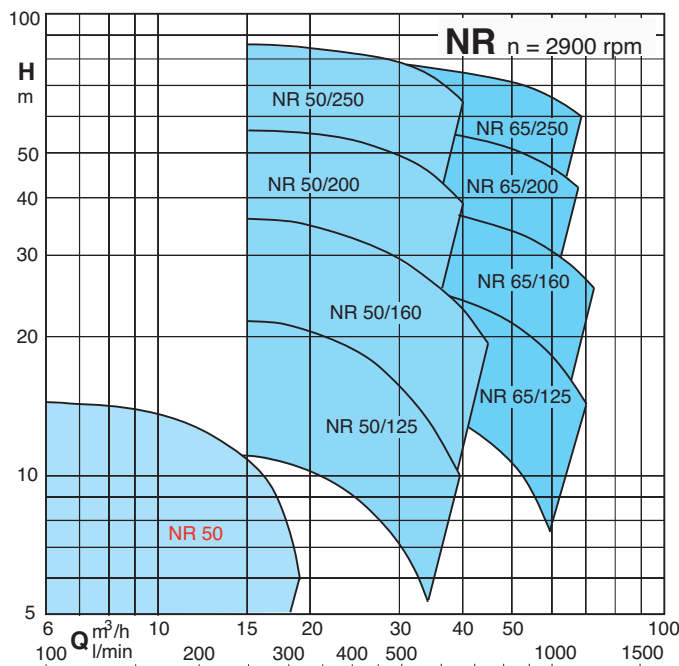

Courbes caractéristiques n ≈ 2900 1/min

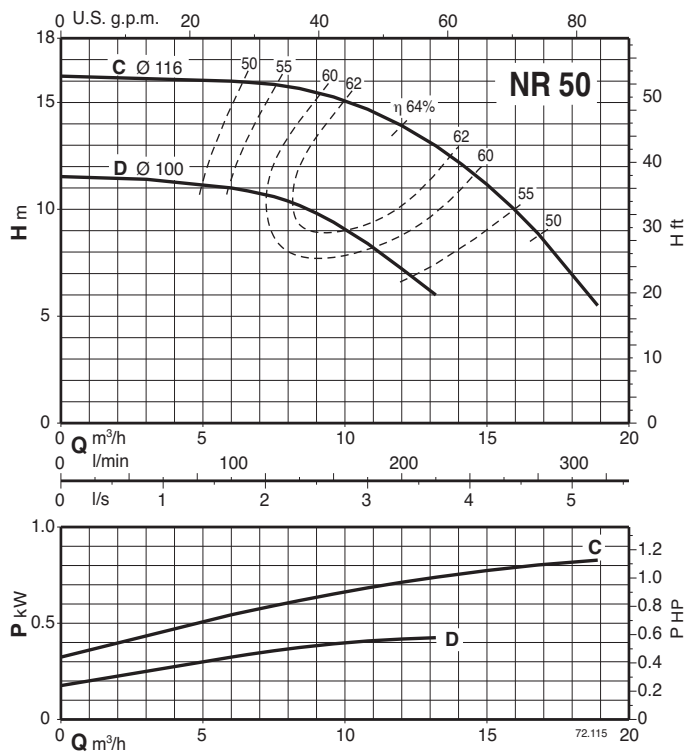

Courbes caractéristiques n ≈ 2900 1/min

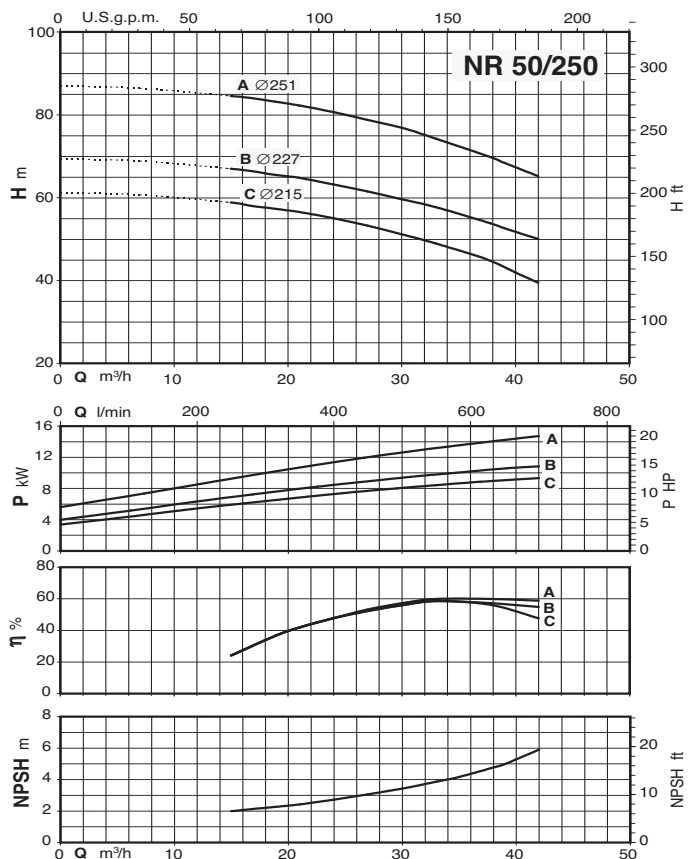
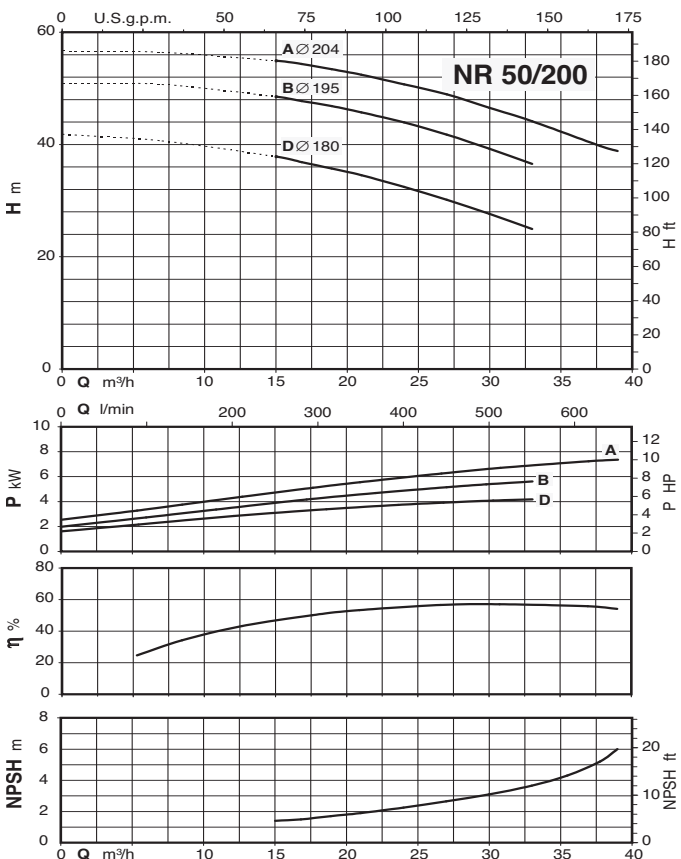
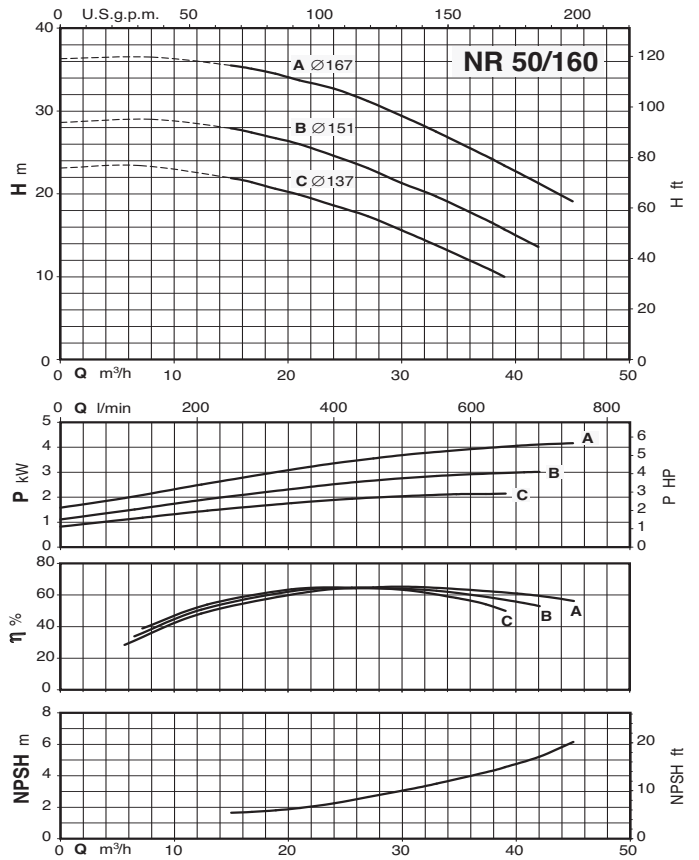
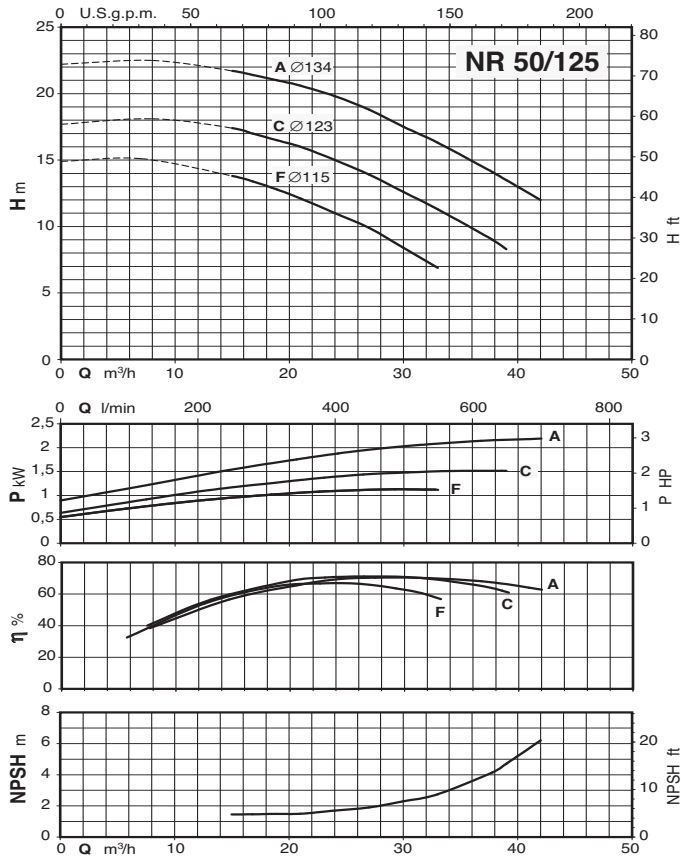

Courbes caractéristiques n ≈ 2900 1/min

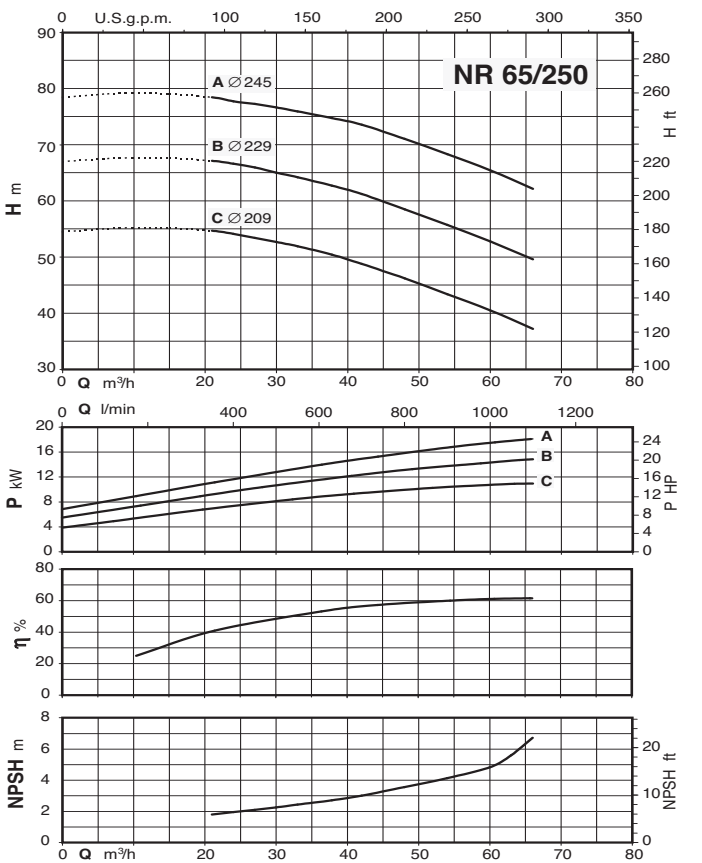
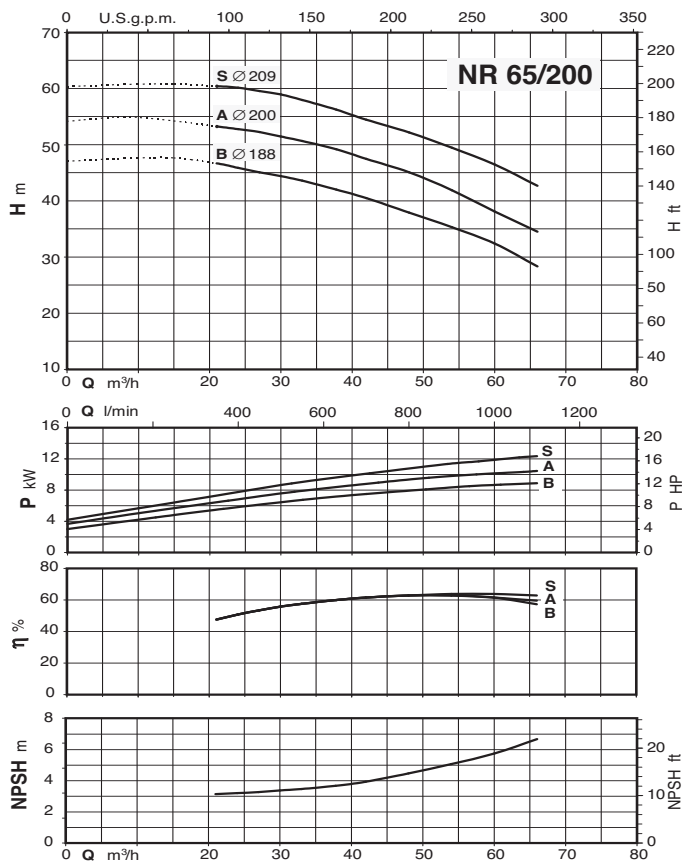
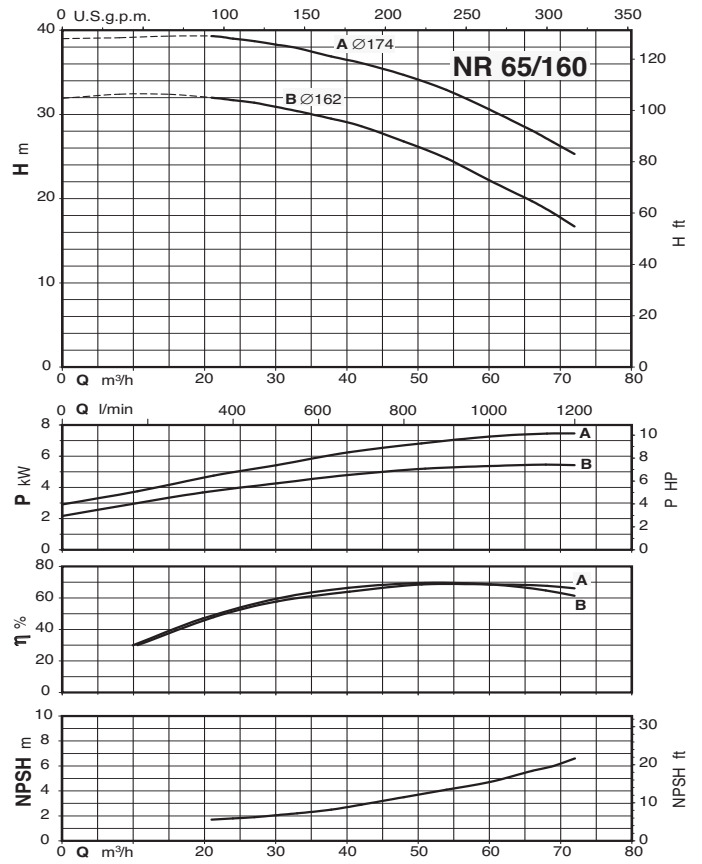
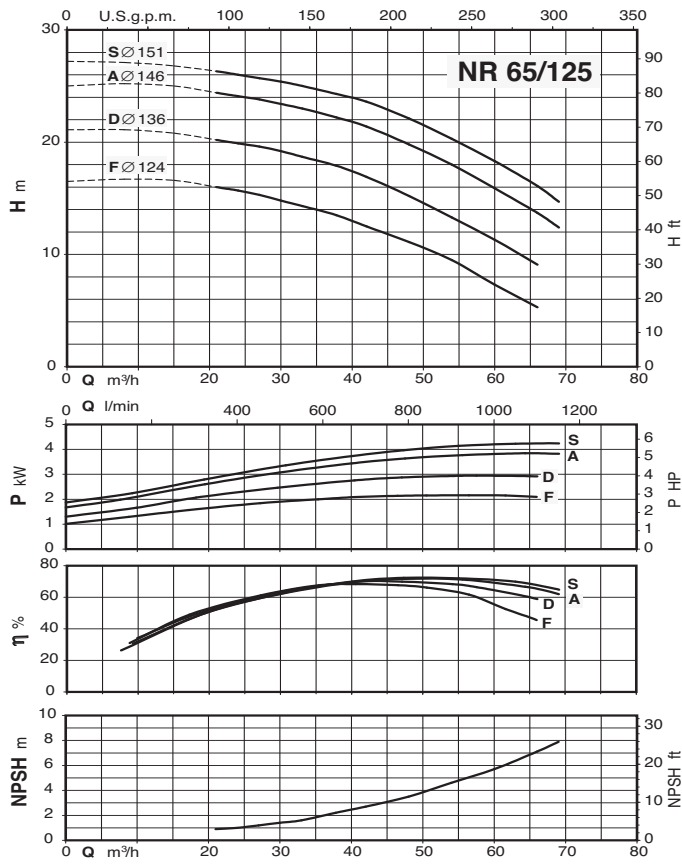

Courbes caractéristiques $n \approx 1450$ 1/min

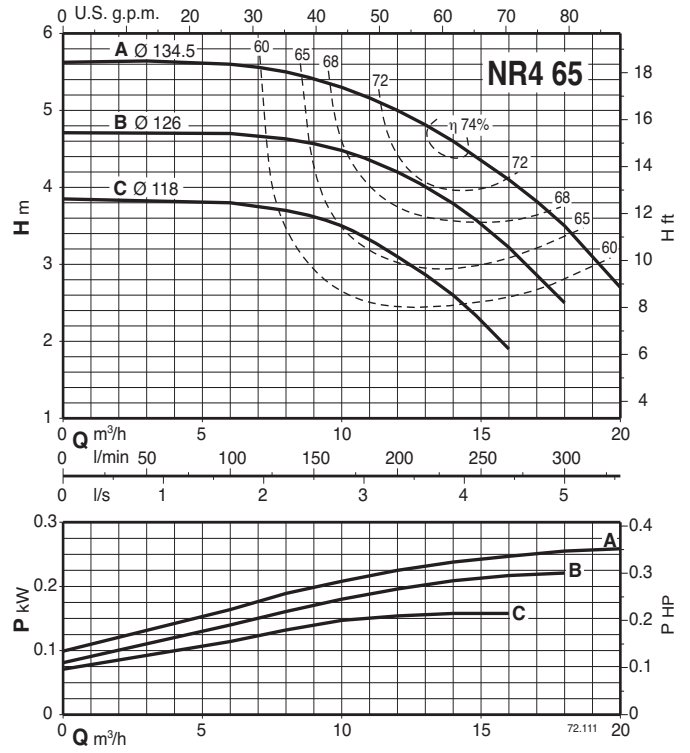
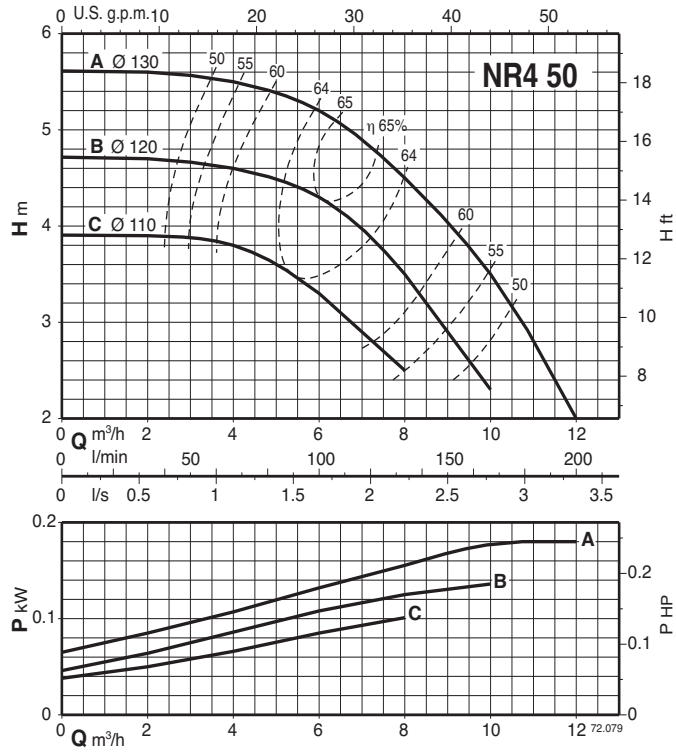

Courbes caractéristiques $n \approx 1450$ 1/min

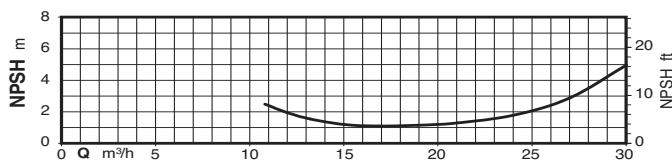
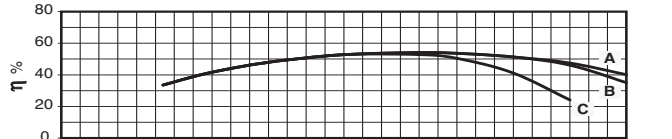
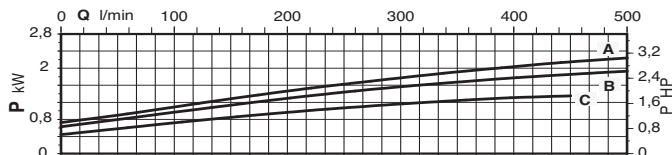
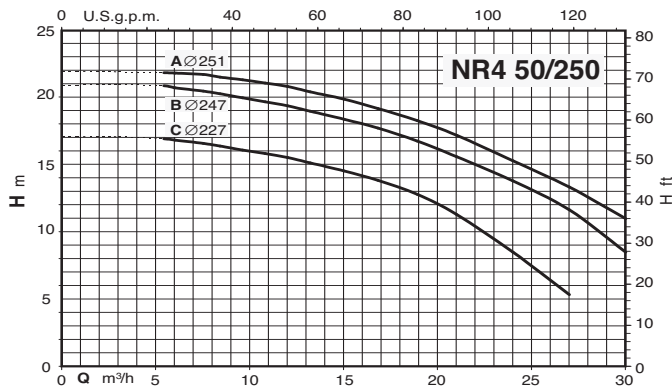
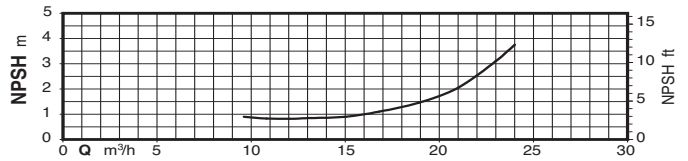
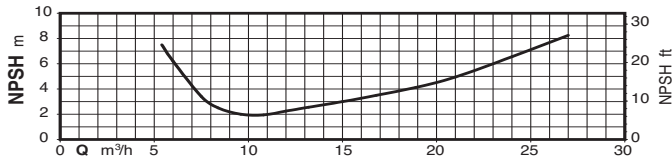
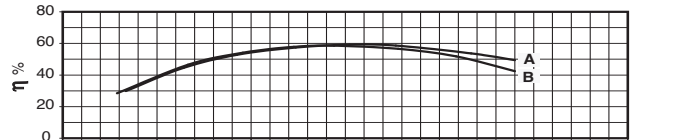
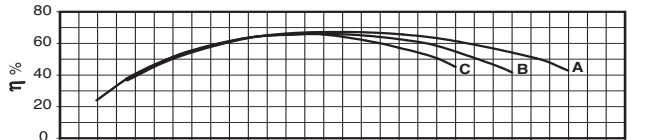
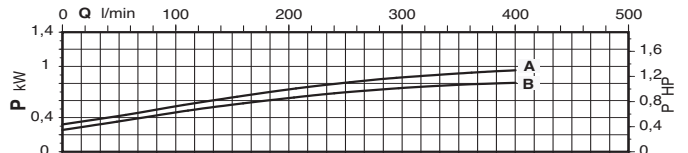
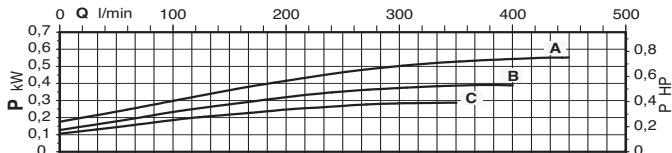
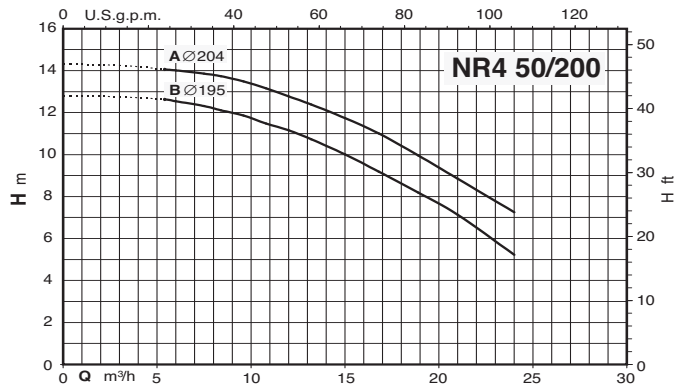
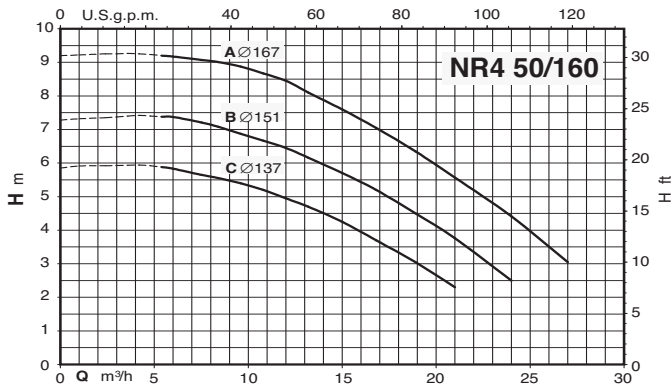

Courbes caractéristiques n ≈ 1450 1/min

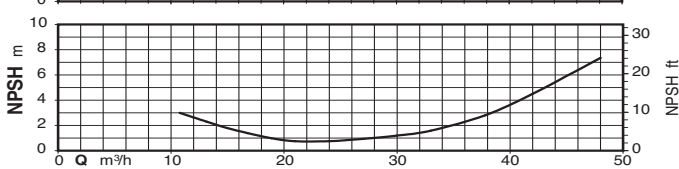
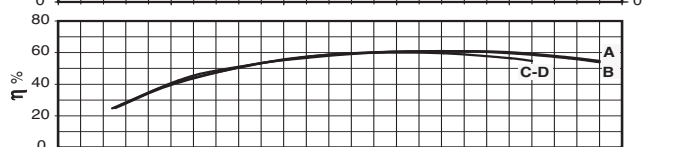
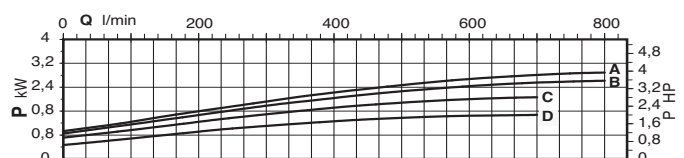
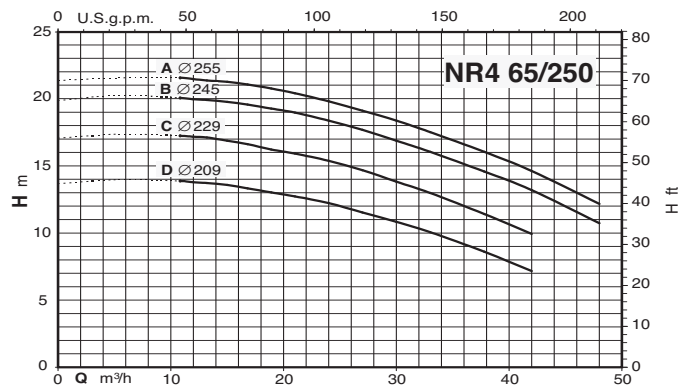
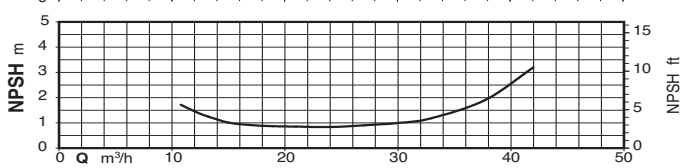
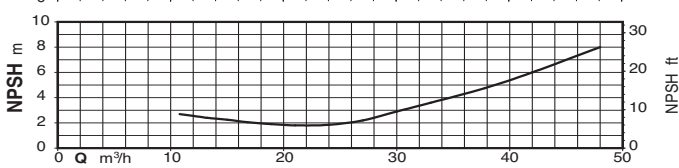
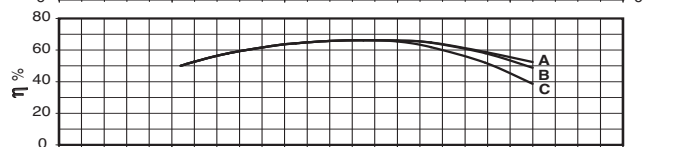
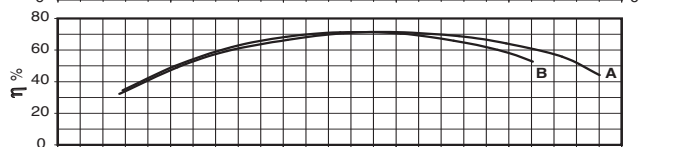
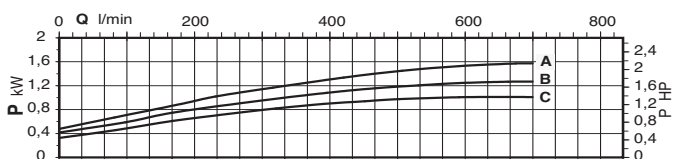
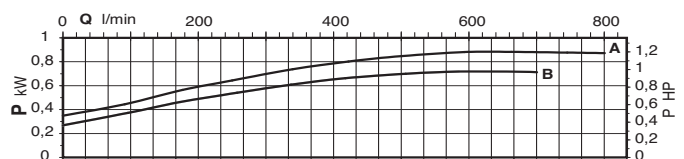
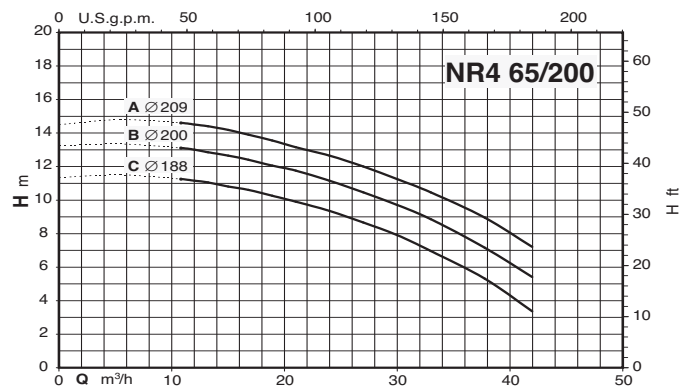
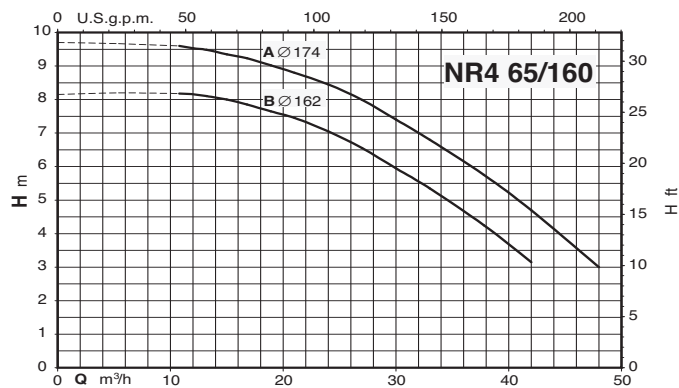

Courbes caractéristiques n ≈ 1450 1/min

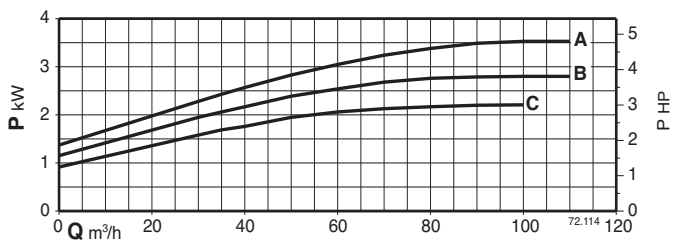
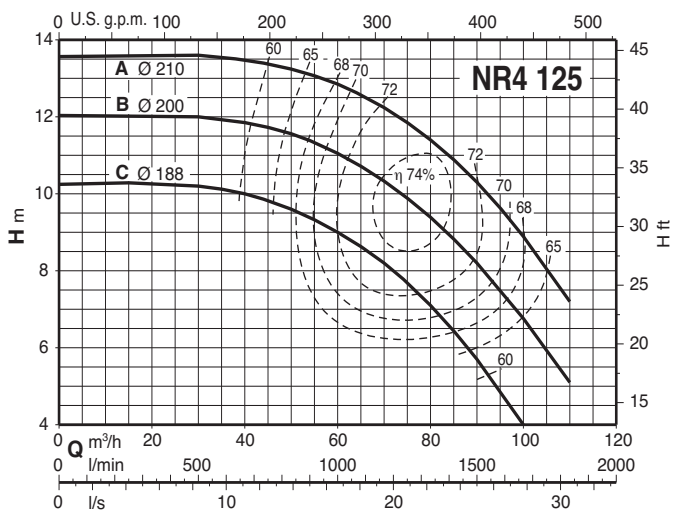
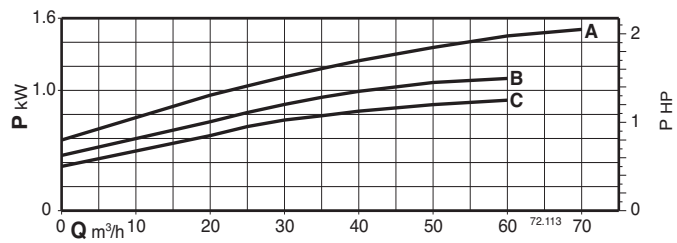
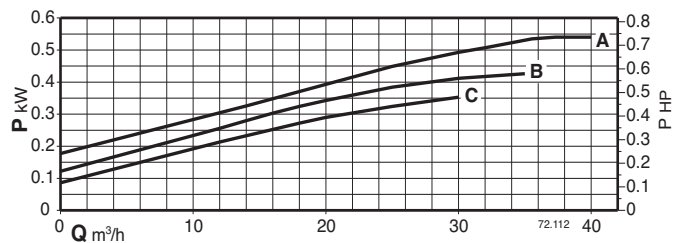
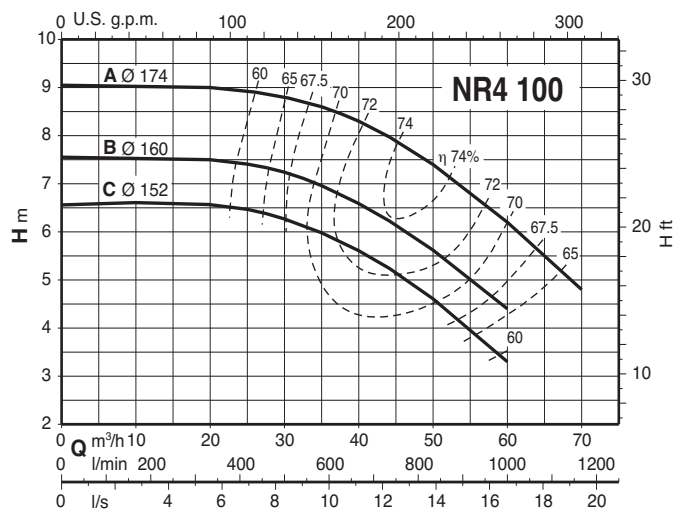
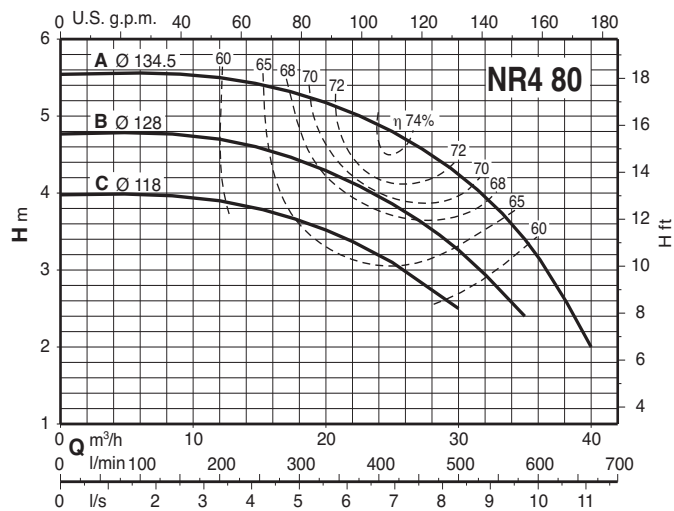

Dimensions et poids

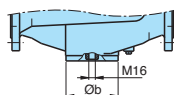
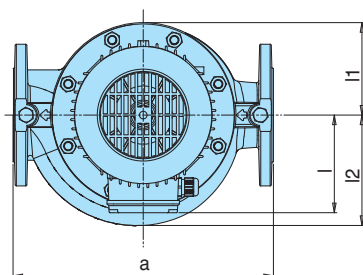
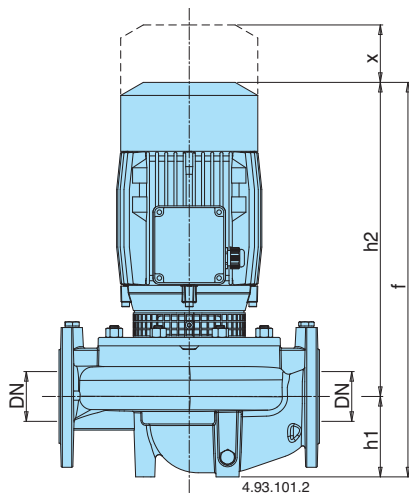

TYPE	mm										kg
	DN	a	f	h1	h2	Øb	l	l1	l2	x	
NR 50D/A-C/A	50	320	360	90	270	98	111	93	100	70	29,5-30
NR 50/125A-C-F	50	340	435	90	345	-	128	96	115	75	33,2-31,5-29,5
NR 50/160C	50	340	437	90	347	-	128	120	128	75	38,7
NR 50/160A-B	50	340	502	90	412	-	128	120	128	75	51,3-47,5
NR 50/200D	50	440	512	100	412	-	128	140	140	80	59,2
NR 50/200A-B	50	440	542	100	442	-	160	140	140	80	76,2-69,2
NR 50/250B-C	50	440	702	100	602	-	185	175	175	85	121-114
NR 50/250A	50	440	742	100	652	-	185	175	175	85	137
NR 65/125F	65	340	452	105	347	-	128	121	145	95	43,1
NR 65/125S-A-D	65	340	517	105	412	-	128	121	145	95	55,6-55,6-51,6
NR 65/160A-B	65	340	549	105	444	-	160	121	142	95	73-67
NR 65/200A-B	65	475	667	105	562	-	185	140	153	90	114-108
NR 65/200S	65	475	722	105	617	-	185	140	153	90	120
NR 65/250A	65	475	672	105	567	-	185	175	175	90	155
NR 65/250B	65	475	722	105	617	-	185	175	175	90	140
NR 65/250C	65	475	747	105	642	-	185	175	175	90	134

TYPE	mm										kg
	DN	a	f	h1	h2	Øb	l	l1	l2	x	
NR4 50A/A-B/A-C/A	50	320	360	90	270	98	111	93	100	70	24-24-24
NR4 65AE-BE-CE	65	360	370	100	270	118	111	102	114	70	28-28-28
NR4 80AE-BE-CE	80	400	445	125	320	130	110	123	140	80	38,5-38-37,5
NR4 100BE-CE	100	500	485	150	335	162	110	153	173	105	59-59
NR4 100AE	100	500	510	150	360	162	140	153	173	105	64
NR4 125CE	125	600	540	160	370	194	140	172	195	120	89
NR4 125AE-BE	125	600	610	160	440	194	170	172	195	120	110-108
NR4 50/160A-B-C	50	340	437	90	347	-	128	120	128	75	37,5-35,5-33,5
NR4 50/200A-B	50	440	447	100	347	-	128	140	140	80	56
NR4 50/250B-C	50	440	552	100	452	-	128	175	176	85	77,5-74,5
NR4 50/250A	50	440	592	100	592	-	128	175	176	85	93,5
NR4 65/160A-B	65	340	454	105	349	-	128	121	142	95	42,7-42,5
NR4 65/200C	65	475	467	105	362	-	128	140	153	90	52
NR4 65/200A-B	65	475	532	105	532	-	128	140	153	90	62-57
NR4 65/250C-D	65	475	517	105	412	-	128	175	175	90	73-73
NR4 65/250A-B	65	475	557	105	557	-	128	175	175	90	98-85

Brides PN 10, EN 1092-2

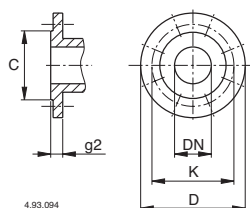

DN	mm					
	C	K	D	Trous N°	g2	
50	99	125	165	4	19	20
65	118	145	185	4	19	20
80	132	160	200	8	19	22
100	156	180	220	8	19	24
125	184	210	250	8	19	24